

Underwater Inductive Modem



SUMMARY

- Integrates RS-232 instruments to Sea-Bird's Inductive Modem (IM) telemetry system
- Internal memory and internal batteries
- Depths to 7000 meters (titanium housing)
- Sea-Bird's field-proven IM telemetry, with more than 3000 Sea-Bird IM instruments deployed since 1997

DESCRIPTION

The SBE 44 Underwater Inductive Modem (UIM) makes it possible to integrate current meters, Doppler profilers, or other instruments having standard serial interfaces with MicroCATs or other instruments that communicate via Sea-Bird's inductive modem telemetry system. The UIM has a built-in inductive cable coupler (split toroid) and cable clamp, providing data communications without the need for electrical connections, and an easy and secure attachment to any point on a jacketed mooring wire. An underwater bulkhead connector on the end cap provides the serial data connection, a control line, and switched power out.

The Inductive Modem (IM) system provides reliable, low-cost, real-time data transmission for up to 100 IM-enabled instruments using plastic-coated wire rope (typically 3x19 galvanized steel) as both the transmission line and mooring tension member. IM instruments clamp anywhere along the rugged mooring wire. Expensive and potentially unreliable multi-conductor electrical cables with fixed-position underwater connectors are not required. IM moorings are easily reconfigured for changing deployments (positions changed or instruments added or removed), by sliding and re-clamping instruments on the cable. Inductive modem systems are much less expensive and more power-efficient than acoustic modems, and offer reliable communication over greater distances.



INDUCTIVE MODEM SYSTEM OVERVIEW

In a typical mooring, an Inductive Modem Module (IMM) or Surface Inductive Modem (SIM) housed in the buoy communicates with underwater IM instruments and is interfaced to a computer or data logger via an RS-232 serial port. The computer / data logger (not supplied by Sea-Bird) is programmed to poll each IM instrument on the mooring for its data, and send the files to a telemetry transmitter (satellite link, cell phone, RF modem, etc.). Communication between the PC / data logger and IMM/SIM is full-duplex RS-232C. Commands and data are transmitted half-duplex between the IMM/SIM and UIM. The UIM interprets the commands, relays correctly addressed commands to the serial instrument, and transmits replies from the instrument to the IMM/SIM. There are two methods of connecting the IMM/SIM to the jacketed wire:

- In a direct connection (typical cable-to-shore applications), the bottom end of the wire is grounded to seawater, and the top end is insulated all the way to the connection to the IMM/SIM. A second wire from the IMM/SIM connects to seawater ground, completing the circuit.
- In typical surface buoys it is often preferable to connect the jacketed mooring wire to the buoy with a length of chain, grounding the wire to seawater at each end. An Inductive Cable Coupler (ICC) connects the IMM/SIM to the jacketed wire above the uppermost IM-enabled instrument and below the point where the wire is grounded.

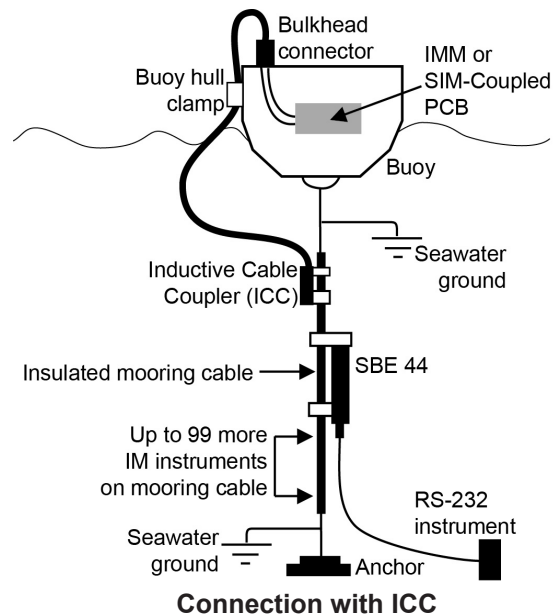
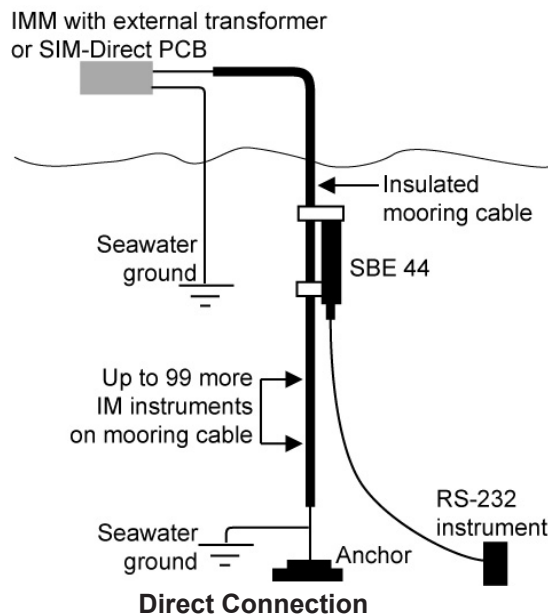

DPSK (Differential Phase Shift Keyed) DATA TRANSMISSION

Sea-Bird's IM telemetry system uses a DPSK data transmission technique to achieve efficient data transmission with low error rates. The Sea-Bird system uses a carrier frequency of 4800 Hz, allotting four cycles of carrier frequency to each data bit. The encoding scheme is straightforward: if the next bit is a one, the phase of the carrier is inverted (shifted 180 degrees); if the next bit is a zero, the carrier phase does not change.

The modulation and demodulation hardware required for DPSK are extremely simple. Modulation requires only an OR gate and flip-flop; demodulation is inherently coherent (bit energy is averaged rather than spot-sampled) using minimal hard logic, a shift register implementing a one-bit delay being the principle component. Sending data containing all zeros results in a single continuous frequency (4800 Hz) being placed upon the transmission cable, which is readily detected by IM instruments as the *wake up* signal. The IM system is designed to be insensitive to the connection polarity of the coupling transformers.

OPERATION

The UIM transmits data over any insulated wire. Communication on a mooring is typically via the jacketed mooring wire. Full ocean-depth mooring cables can be used. The DPSK telemetry system provides a high degree of immunity from *fishbite* or other cable degradation. For laboratory bench testing, simply loop any insulated wire through the inductive toroid and connect the ends of the wire to the IMM/SIM.

Each UIM has a programmable address, allowing up to 100 UIMs (or other instruments compatible with the Sea-Bird inductive modem) to be attached to a single mooring cable. When the UIM receives a command containing its unique ID, it relays the command to the serial instrument and then transmits the reply over the inductive link. A 30 Kbyte FIFO buffer allows the UIM to interface to serial instruments at 300, 600, 1200, 2400, 4800, 9600, or 19200 baud while transmitting data at 1200 baud over the IM link. Programmable setup parameters stored in EEPROM include timeout values, control signal logic, and sensor response termination logic, allowing the UIM to interface to a wide variety of instruments without requiring custom programming.

The UIM can be externally powered, and can provide power to a serial instrument from the external source or its internal battery pack, via the bulkhead connector's *switched power output* pins. The UIM is powered by a battery pack consisting of twelve AA lithium batteries (Saft LS14500) which, when removed from the UIM, can be shipped via commercial aircraft. The internal battery is diode-OR'd with the external supply, so whichever voltage is higher will be available to power another instrument.

UIM SPECIFICATIONS

Sensor Interface: RS-232 standard; RS-485 optional

Power:

- Quiescent current: < 100 microAmps
- Operating current: 10 milliAmps
- Maximum current to serial instrument: 1.5 Amps

Power Supply: 10.6 Amp-hour (nominal) battery pack, derated to 8.8 Amp-hour (if not supplying power to serial instrument) or 5.7 Amp-hour (if supplying power to serial instrument)

Materials: Titanium housing

Depth Capability: 7000 meters (23,000 feet)

IMM, SIM, AND ICC SPECIFICATIONS — Available separately

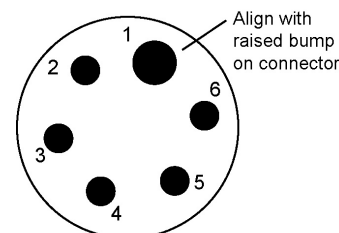
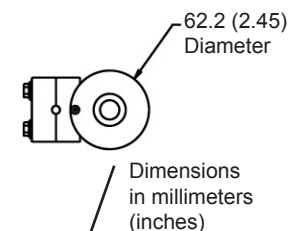
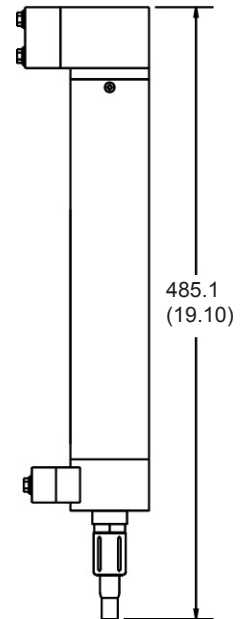
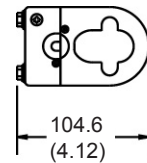

**Standard Connector
AG-306-HP**

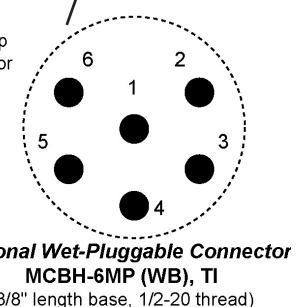

**Optional Wet-Pluggable Connector
MCBH-6MP (WB), TI**
(3/8" length base, 1/2-20 thread)

Pin	Description
1	Common
2	RS-232C Receive from serial instrument
3	RS-232C Transmit to serial instrument
4	Switched power out (optional)
5	Control signal (optional)
6	External power in (10-20 VDC) (optional)

