



SEA-BIRD ELECTRONICS, INC.

1808 136th Place N.E., Bellevue, Washington 98005 USA
Telephone: (425) 643-9866 Telex: 292915 SBEI UR
Fax: (425) 643-9954 email: seabird@seabird.com

SBE P/N 50121

DATE	SYM	REVISION RECORD	AUTH	DR	CHK
06.03	A	Clarify clamp and CTD positioning	MJ	MV	
9.04	B	Changed Clamp	CB	KLP	

SBE32 Carousel to CTD Mount Bar Kit

Kit Contents

SBE P/N	Manufacturer P/N	Primary SBE Application	QTY
23746	SBE 32 to Seacat/Prof. mount bar	Main sensor mount bar, Celcon	1
23838	SBE-32 to Seacat/Prof. mount pin	Installs on top of mount bar	1
30259	Washer, 1/2" flat, narrow	Washer for lock washer / mount bar interface	1
30409	Teflon tape	Lines hose clamps for protection	3'
30594	Washer, 1/2 split ring	Washer for flat washer / mount pin interface	1
30603	Screw, 1/2-13 x 3-1/2" SS	Secures mount pin, washers, to mount bar	1
30988	Hose Clamp, AWAB 316 SS, #80	Clamps SBE 19 to Mount bar	2

Procedure for Mount Bar Assembly

Refer to drawing number 67020B

A. Assembling the Mount Bar

- Clean hose clamps with Alcohol, to remove any oils, or dirt.
- Cut 2 lengths of Teflon tape, 15"**, and tape the inside of the hose clamp.
 - Tape should start by covering clasp area, and wrapping around toward open end.
 - There should be 2-3" at least of bare metal at the open end of the hose clamp.
 - Use a sharp blade to trim off any excess tape hanging over hose clamp sides.
- Tighten the 1st 2 or 3 threads of hose clamps** together. Clamps will fit around the mount bar, as shown on drawing 67020A.
- Slip Seacat through Clamps**, and tighten clamps. Screws on hose clamps should face toward the outside of the carousel system, when installed. (for ease of installation and removal)
 - Metal units may be tightened as far as the assembler desires.
 - Plastic units must be in the range of snug plus about 1/2 to 1 turn farther on the hose clamp.
- Seacat is now secure** on the mount, and may replace any 1 bottle on the carousel frame.
- If unit will not be installed right away**, install mount pin assembly now.
 - Slip lock washer (30594), flat washer (30259), and mount (23838) in order over bolt (30603).
 - Fill bolt socket with DC-4, or other SILICON lubricant, for displacing water that will attempt to penetrate.
 - Insert bolt/pin assembly from the top, and secure with a socket hex key.
 - Tighten bolt into top end of mount bar (23746) just until lock washer is flush.

B. Installing Seacat onto Adapter plate

- Install CTD system to an open space where there are **no latches**.
- Make sure there is no latch on the pylon where you are placing the CTD.
- Set the lower brace of the mount bar onto a pin on the bottom plate.
- Move CTD in toward upper plate. Lower brace will drop onto pin as you go.
- Fit CTD into space between plates, and line up holes.
- Optimally, top of CTD (Battery end) will sit just above the upper adapter plate. This way, it is easy to replace the batteries.
- Insert bolt/pin assembly from the top, and secure with a socket hex key.
- Tighten this connection fully*

Parent Part Number: 50121

SBE Drawings:

67020B SBE 32 to CTD Mount Kit Assembly

Sea-Bird Electronics Procedure

PROCEDURE NUMBER: **67020**

TITLE: **SBE CTD to Carousel Mount Bar Kit**

REVISION: **B** Written: **11.07.2002**

REVISION DATE: **09.02.2004**

CHECKED BY:

PAGE 1 of 1

DATE	SYM	REVISION RECORD	AUTH.	DR.	CK.
06.03	A	Added Seacat Bar	MJ	MV	
9.04	B	Changed Clamp	CB	KLP	

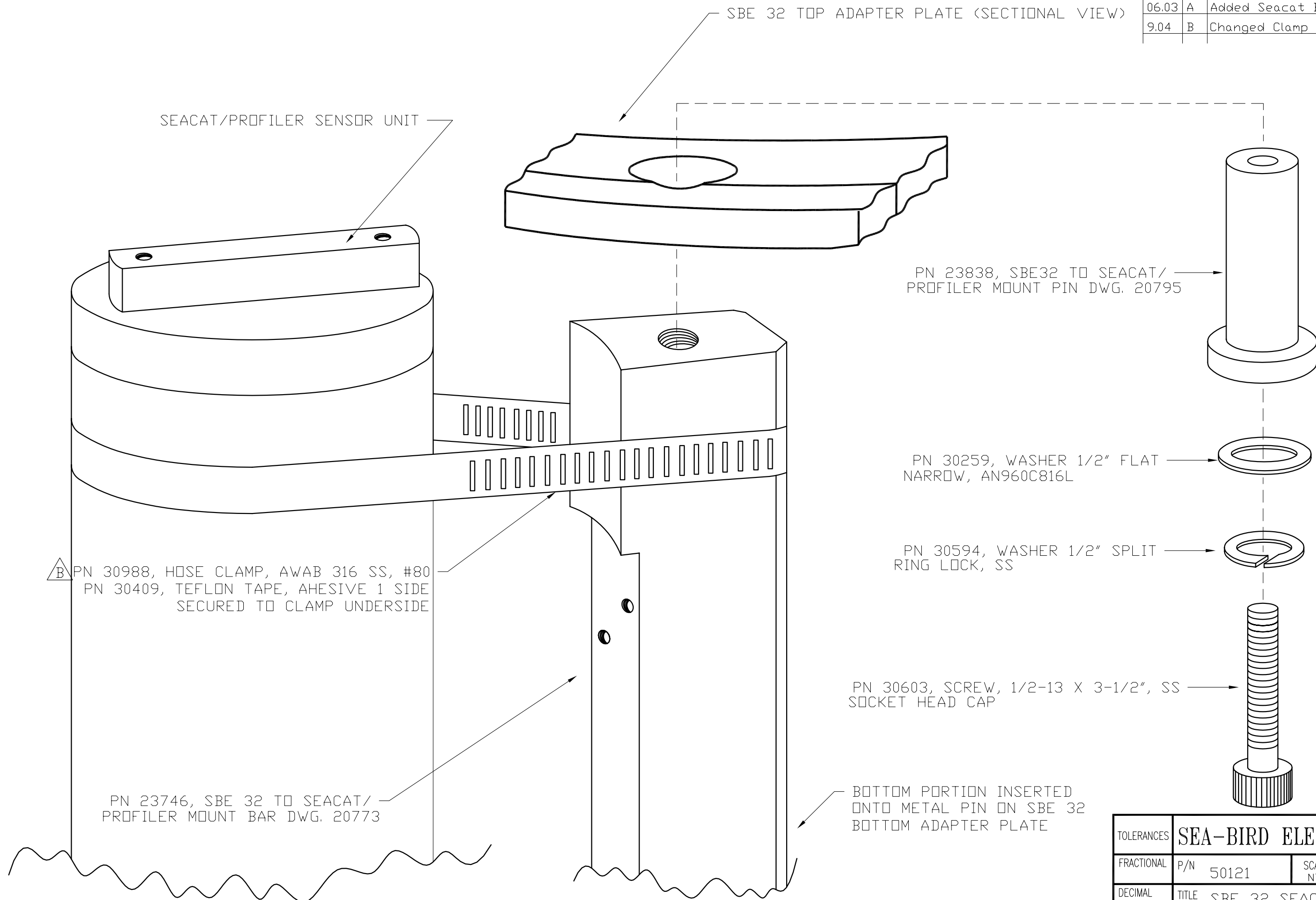

SEACAT/PROFILER SENSOR UNIT

SBE 32 TOP ADAPTER PLATE (SECTIONAL VIEW)

PN 23838, SBE32 TO SEACAT/
PROFILER MOUNT PIN DWG. 20795

PN 30259, WASHER 1/2" FLAT
NARROW, AN960C816L

PN 30594, WASHER 1/2" SPLIT
RING LOCK, SS

PN 30603, SCREW, 1/2-13 X 3-1/2", SS
SOCKET HEAD CAP

PN 30988, HOSE CLAMP, AWAB 316 SS, #80
PN 30409, TEFLON TAPE, AHESIVE 1 SIDE
SECURED TO CLAMP UNDERSIDE

PN 23746, SBE 32 TO SEACAT/
PROFILER MOUNT BAR DWG. 20773

BOTTOM PORTION INSERTED
ONTO METAL PIN ON SBE 32
BOTTOM ADAPTER PLATE

TOLERANCES	SEA-BIRD ELECTRONICS, INC				
FRACTIONAL	P/N	50121	SCALE	DRAWN BY CEG	
			NTS	APPROVED BY	
DECIMAL	TITLE	SBE 32 SEACAT/PROFILER MOUNT KIT ASSEMBLY			
ANGULAR	DATE	DRAWING NUMBER	67020	REV	B
	5.22.98				