

DATE	SYM	REVISION RECORD	AUTH.	DR.	CK.
03.02	A	Add Adhesive Tubing	MJ	CB	
6.24.02	B	CHANGED RMG TO PMG	CB	KLP	
9.3.02	C	CHANGED DIM B & FALMAT REV		KLP	
9.23.02	D	ADDED LENGTH TO HOLLOW BRAID		KLP	
10.11.02	E	CHANGED CABLE BREAK STRENGTH		KLP	
7.17.06	F	ECN 971, ALT WIRE COLOR		CB	
9.21.06	G	ECN 997, REMOVED BREAKING STRENGTH	CB	KH	
8.01.07	H	UPDATED TO SHOW BRAID SUBASSEMBLY	CB	PC	
8.30.07	J	NEW REV FOR FALMAT CABLE	CB	PC	

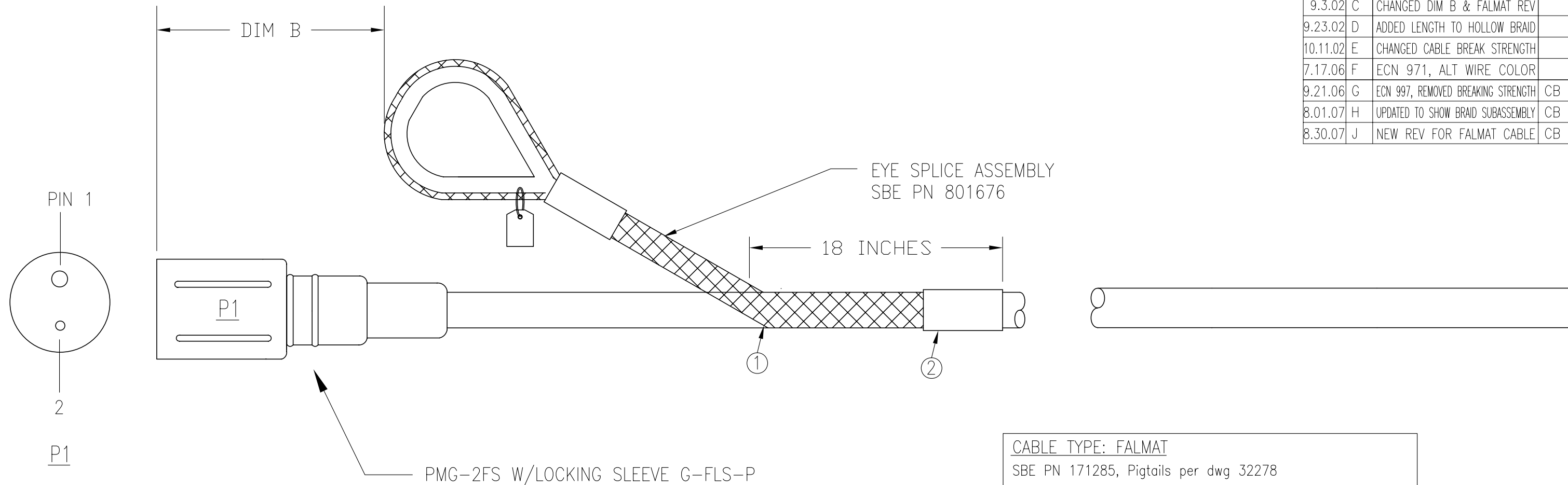

**BRAID AND LIFT-EYE INSTALLATION**

- 1 BRING CABLE THROUGH BRAID  
20 +/- 2 INCHES BEHIND EYE
- 2 1/2" DIA. HEATSHRINK ADHESIVE TUBING 3", PN 31568
- 3 INSTALL CONNECTOR AFTER INSTALLING BRAIDED SPLICES

**CABLE TYPE: FALMAT**  
 SBE PN 171285, Pigtails per dwg 32278

FM020999SA1 REV. C  
 POLYURETHANE, KEVLAR REINFORCED, 3 CONDUCTOR, 22 AWG.  
 YELLOW JACKET, NOMINAL O.D. = 0.270 IN.  
 100 LBS. WORKING LOAD (45 Kg)  
 4 INCH MINIMUM BEND RADIUS (10 cm)

SBE PN	DIM A	DIM B
801202	200 FT / 60 m	52 in
801245	165 FT / 50 m	52 in
801353	231 FT / 70 m	52 in

P1 PMG-2FS	WIRE COLOR	ALT WIRE COLOR
PIN 1	WHITE & WHITE/BLACK	WHITE & BLACK
PIN 2	WHITE/RED	RED

TOLERANCES	<b>SEA-BIRD ELECTRONICS, INC</b>			
FRACTIONAL	P/N	SCALE	DRAWN BY MJ	
	SEE TABLE	NTS	APPROVED BY	
DECIMAL	TITLE CABLE: PMG-2FS LOAD-BEARING PIGTAIL POLYURETHANE, KEVLAR REINFORCED			
ANGULAR	DATE	DRAWING NUMBER	REV	
	01.11.00	32358	J	